

CNC

# 5000 Series Router

Reliable turnkey solutions for any application requiring value, performance and versatility.



**MULTICAM**  
Complete CNC Solutions

# RUGGED, RELIABLE...

# ...& BUILT TO LAST

## 5000 SERIES ROUTER

The MultiCam 5000 Series CNC Routers are extremely flexible machines. We designed them for easy configuration to meet high-speed routing application requirements. Use this rugged cutting system in a broad range of woodworking, plastic, and non-ferrous metal production needs.

Rigid all-steel construction and a space-saving, moving gantry design make the 5000 Series robust, commercial-grade machines designed for heavy-duty CNC routing. With the industry's largest range of standard table sizes and spindle configurations, MultiCam's 5000 Series is an ideal choice in today's competitive manufacturing environment.



## FEATURES & SPECIFICATION GUIDE

PERFORMANCE / EASE OF USE / PRODUCTIVITY

# FEATURES

No machine offers more features than the innovative and versatile 5000 Series Router.



## Gantry Engineered for Performance

The gantry is fabricated from 8" x 12" structural steel tubing with 0.625" welded bard stock supporting the linear rails. This assembly is stress relieved prior to precision machining.

Y axis features 25-mm linear rails, ac brushless servos, precision planetary gearboxes plus helical rack and pinion.



## Gantry Supports High Strength, Minimal Vibration

The gantry supports are precision machined from cast iron tooling plate, using a 4-Axis horizontal machining center to guarantee perpendicularity. The cast iron support has inherent vibration dampening characteristics while giving rigid support to the gantry tube.

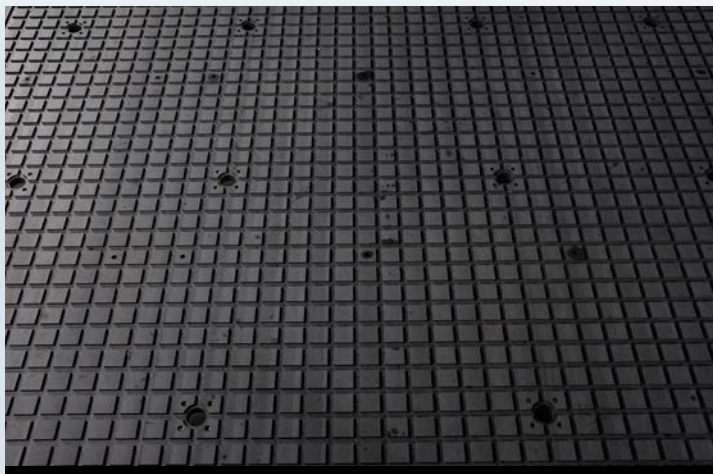

## Working Surfaces Versatile, Effective, Multi-functional

The standard working surface is 1" thick 80-82 Durometer phenolic with a machined 1.5mm grid pattern utilizing .25" x .5" foam gasket tape. Phenolic makes an excellent work surface because of its dependable mechanical strength and dimensional stability.



## Base Frame Solid, Heavy-Duty Construction

The base frame is a one-piece plate steel frame that is welded, stress-relieved and precision machined. One-piece construction allows for a very accurate, rigid and smooth cutting system, while essentially removing the possibility for any after installation errors that could affect the performance and accuracy of the system.



# FEATURES

No machine offers more features than the innovative and versatile 5000 Series Router.



## Vacuum Pumps **Optimum Performance**

Standard vacuum pump options include an 8.5 HP (225 CFM) or 17 HP (335 CFM), two stage regenerative blower. These heavy-duty pumps will maximize material hold down and are designed for optimal performance on a wide variety of materials. Other pump options available based on application.



## EZ Control **Easy-To-Use**

MultiCam EZ Control is one of the most powerful yet easy-to-use motion control systems available on the market. Allows for multiple job reference positions as well as automatic Z surfacing, electronic depth safety system, proximity restart and cut speed & spindle RPM override.



## Linear Bearings **Fluid & Accurate**

The 25mm linear bearing profile rails with stainless spring steel strip covers are standard in the X, Y & Z axes.

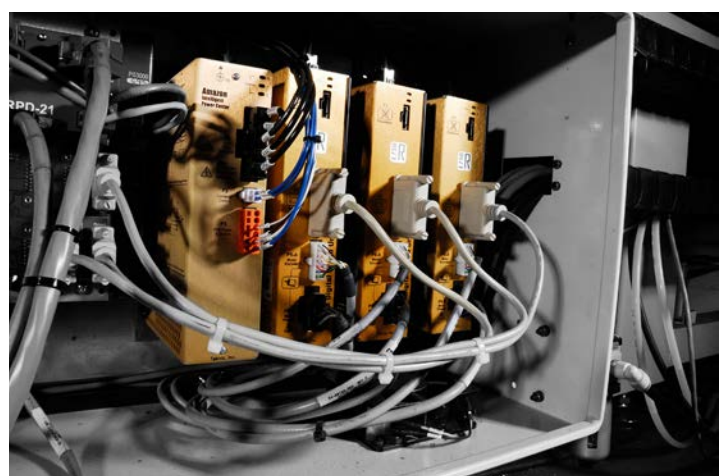

## Digital Servo Drive System **Smooth & Reliable**

Digital Servo drives and brushless digital ac servo motors form a digital vector servo drive system that is standard on all 5000 Series machines. This drive system integrates position, velocity, and torque loops seamlessly to provide uncompromised tracking accuracy, smoothness, and reliability.

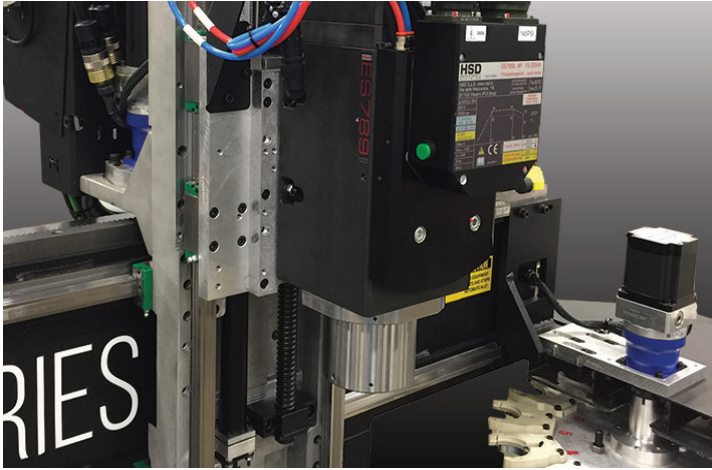

### Router Spindles

#### High Speed for Increased Productivity

The standard spindle is an air cooled, 5.5 HP ISO25, 24,000 RPM, 100% Duty Cycle spindle with a tool diameter capacity of up to 5/8" (16mm). Other available options include a 10 HP ATC spindle.

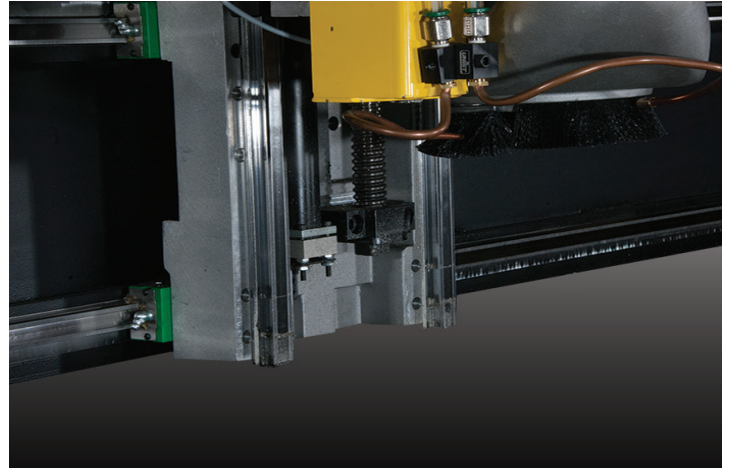

### Z -Axis Assembly

#### Precise & Robust

The 5000 Series Ball Screw Assembly has an available 17" of stroke that is ideal when using specialty tools. It allows for the option of adding larger gantry clearance in the field. Gantry riser blocks are available to increase the throat of the machine by 4" or 8".

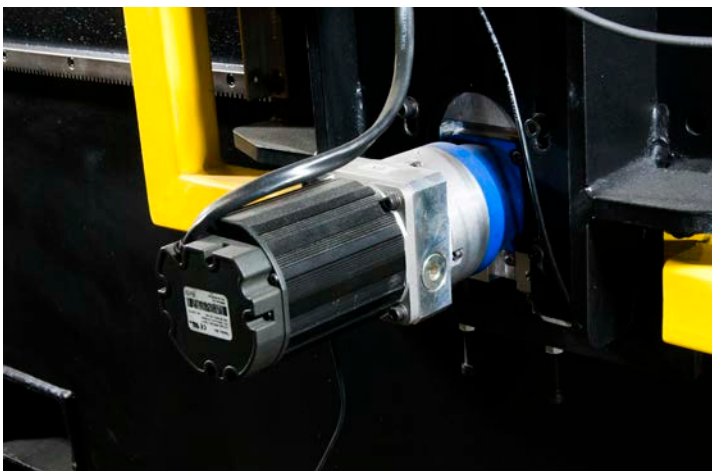

### Drive Assembly

#### High Acceleration, Excellent Cut Quality

High-torque, brushless digital ac servo motors coupled to zero backlash Alpha gearboxes drive both the X and Y axes. This results in high acceleration of the gantry as well as excellent cut quality.

# OPTIONS

The 5000 Series provides a number of options to optimize your throughput and production capabilities.



MultiVision Digital Registration  
**Flexible & Exact**

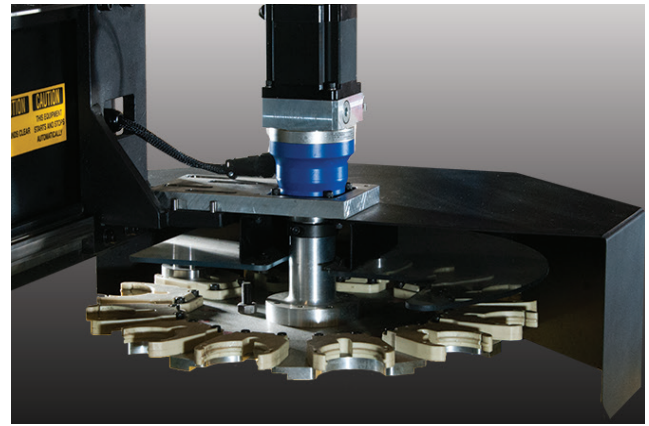

Automatic Tool Changer  
(ATC)  
**Optimized for Faster Throughput**

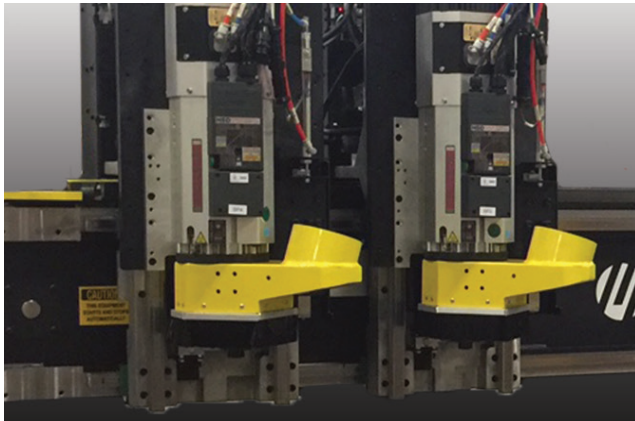

Dual Head  
**Increased Capabilities**



Tangential Knife  
**Versatility to Meet Demand**

## **Other available options:**

- Drill and Tap Spindles
- Z-Axis Dust Boot
- 20:1 Precision Gearbox Upgrade
- Drill Bank

- Motorized C-Axis for Aggregates



# SPECIFICATIONS

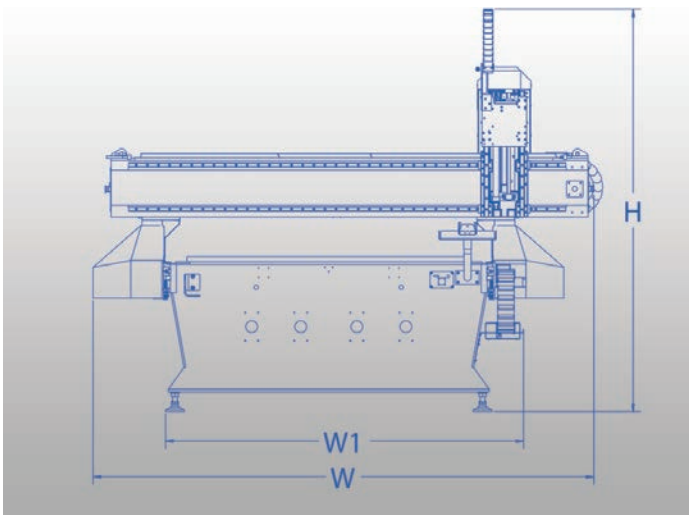
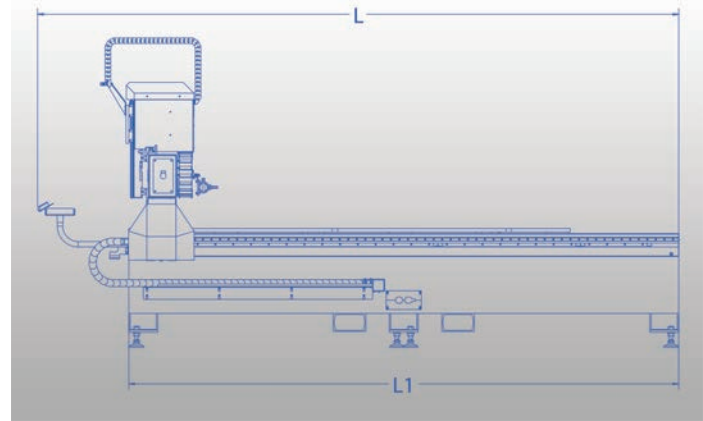
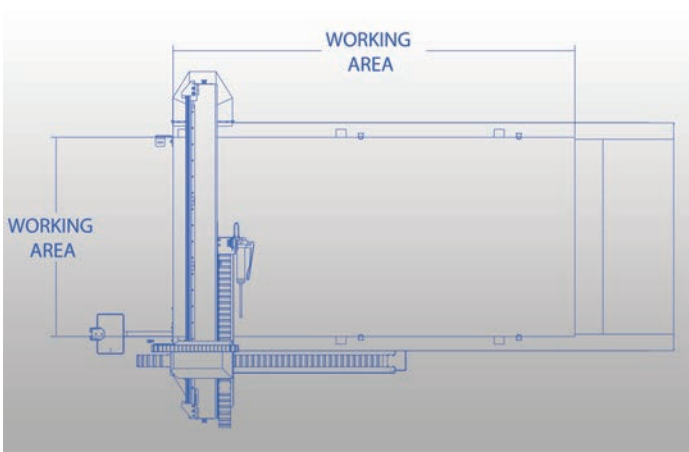

Specifications	Inches	Metric
Z-Axis Clearance	8" *	114mm
Z-Axis Travel	17"	152mm
Slew	2700 IPM	28.702 MPM
Drive System (X,Y)	Helical Rack	Helical Rack
Drive System (Z)	Ball Screw	Ball Screw
Standard Work Surface	1" Phenolic	1" Phenolic

\*Optional 12" or 16"

Model	L (in/mm)	L1 (in/mm)	W (in/mm)	W1 (in/mm)	H (in/mm)	Working Area (in/mm)
5-204	184/4674	152/3861	99/2515	76/1930	86/2184	60.5 x 122 / 1537 x 3099
5-205	202/5131	170/4318	99/2515	76/1930	86/2184	60.5 x 145 / 1537 x 3683
5-304	184/4674	152/3861	119/3023	96/3023	86/2184	80 x 122 / 2032 x 3099
5-305	202/5131	170/4318	119/3023	96/3023	86/2184	80 x 145 / 2032 x 3683
5-308	300/6807	268/6807	119/3023	96/3023	86/2184	80 x 242 / 2032 x 6147

\*\*Other models available



**MULTICAM**  
Complete CNC Solutions

1025 West Royal Lane  
DFW Airport, TX 75261



By phone:  
+1 972.929.4070  
Hotline:  
855.894.3136



By email:  
[sales@multicam.com](mailto:sales@multicam.com)



Or online at:  
[www.multicam.com](http://www.multicam.com)