

Technical Overview

L3 Digital Cutter



Your first choice in digital cutting.

L3 Leather Cutter

Characteristics that excite

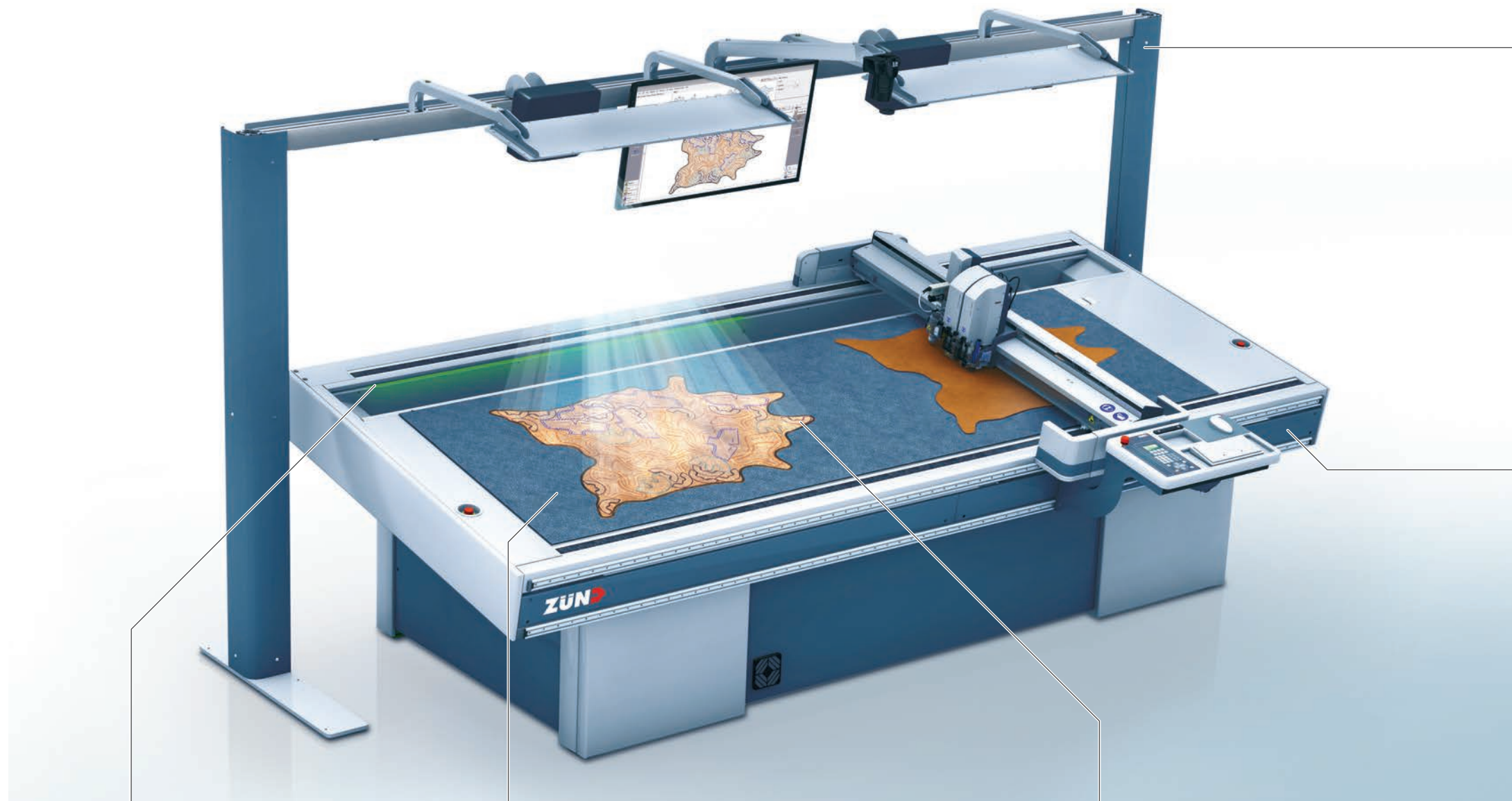

Projection system

The projection system visually supports the user through all phases of production: from setup and automatic or interactive nesting, to picking/sorting of cut parts.

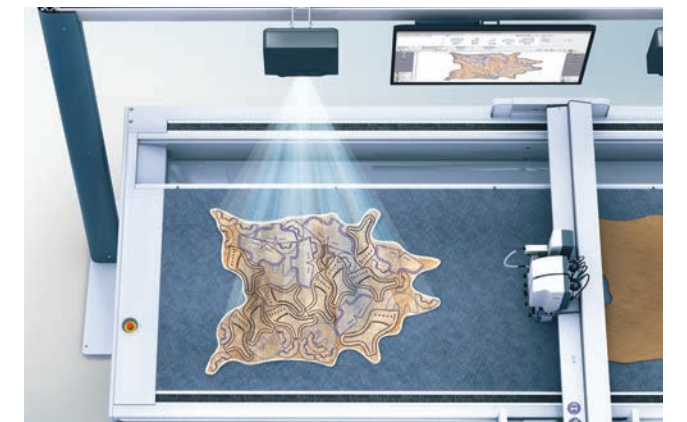

Speed by design

The exceptional productivity of the L3 cutter stems from its smart motion control, precise drive system and fine-tuned cutting technology.

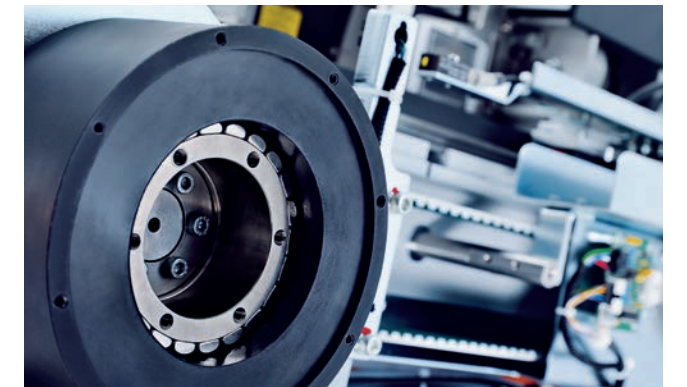

Workflow efficiency

Production and loading/unloading of materials occur at the same time. A green LED light signals which area can be safely accessed at any given time.

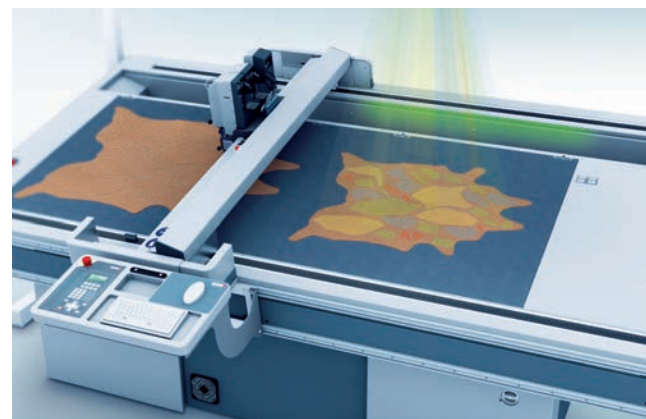

Cutting surface

The cutting surface consists of a highly stable, perfectly constructed aluminum composite and delivers products that are cut to perfection.

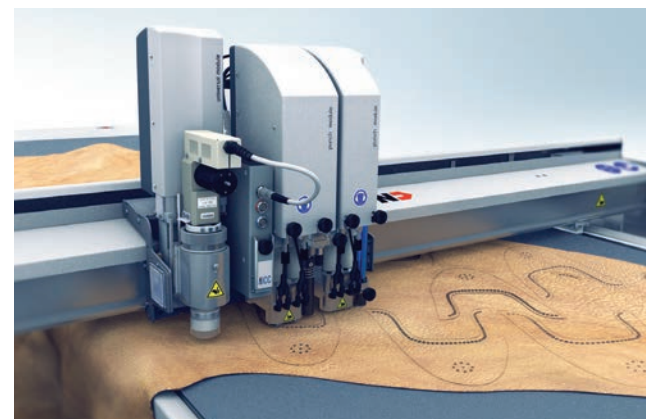

Material hold-down

The cutting surface is divided into individually controllable vacuum zones. A stepless variable vacuum turbine ensures the leather stays firmly in place during processing.

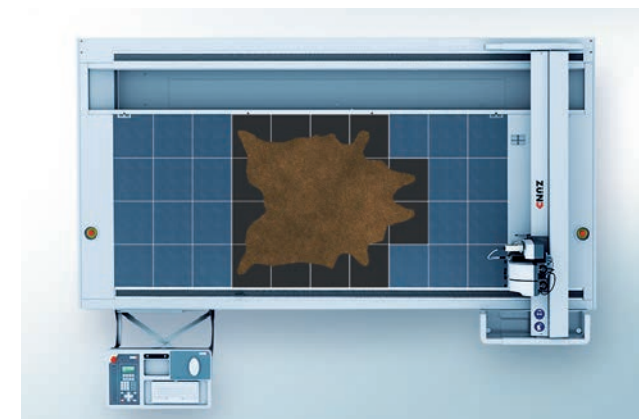

Reliably precise

Zünd cutters are production machines. All components – from the drive system to the blades – are perfectly coordinated for superior performance. This ensures you can complete orders quickly and efficiently and convince your customers with perfect results.

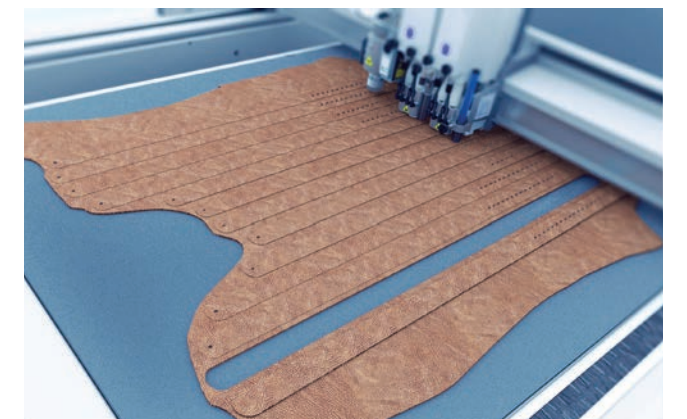

The Zünd building-block design

Variable and efficient

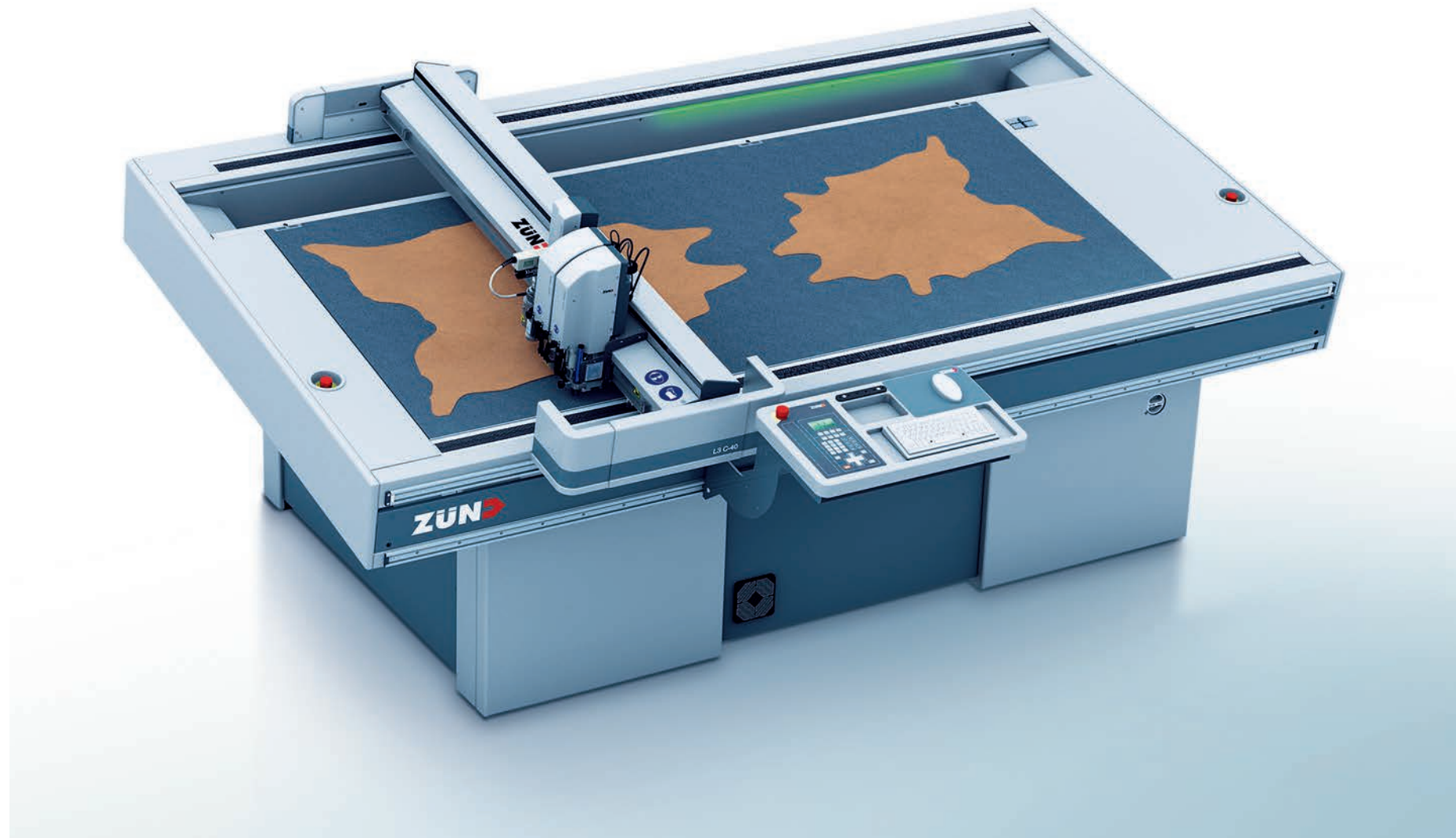

The Zünd tooling system consists of high-performance cutting, punching, and routing tools. The modularity of the system minimizes the initial cost and lets you tailor the configuration to your specific needs. The L3 can accommodate combinations of up to seven tools for different functions.

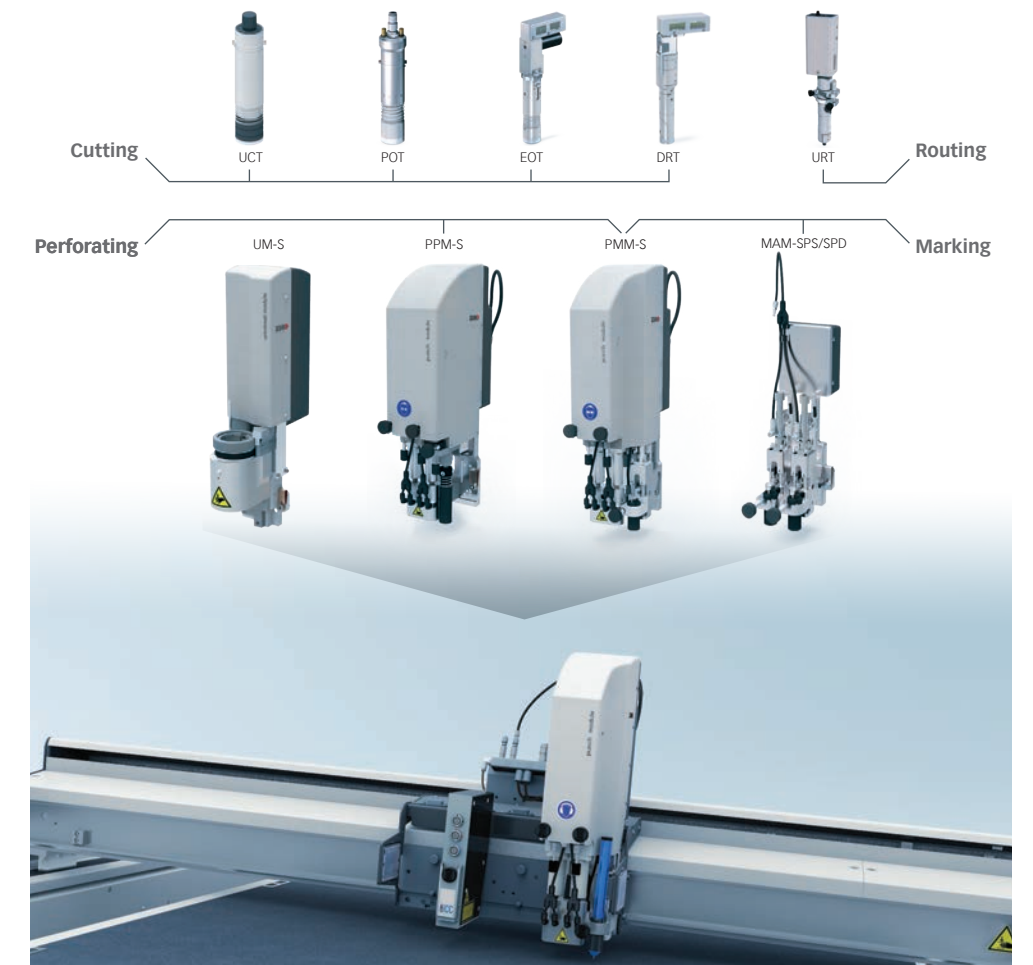

Cutting detailed contours

The Electric Oscillating Tool - EOT is ideal for cutting soft to moderately dense leather materials and detailed contours. High oscillating frequencies permit very high processing speeds.

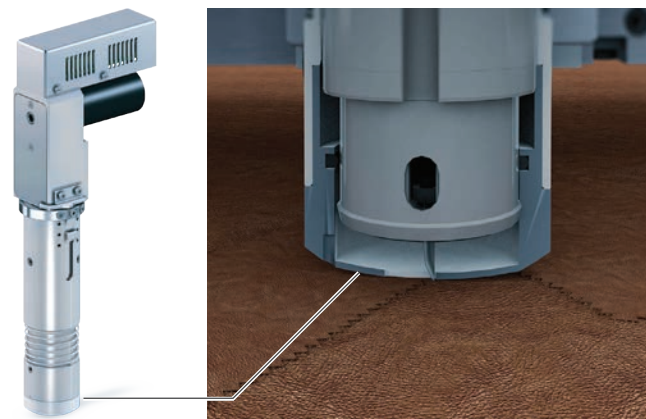

Cutting thick, tough leather

The air-driven Pneumatic Oscillating Tool - POT with a powerful 8 mm stroke is particularly well suited for processing dense, tough materials such as those used for soles.

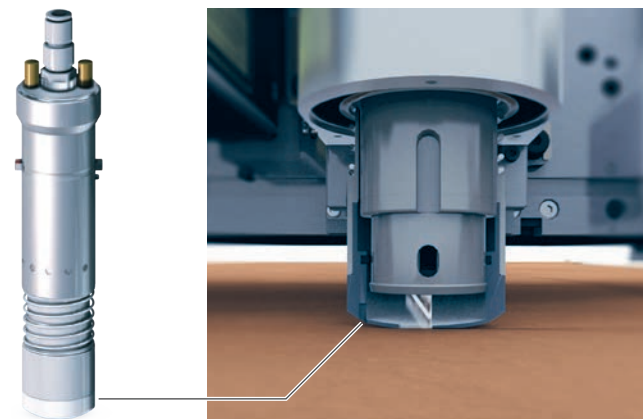

Perforating

The Zünd high-performance tools for perforating leather, rubber and textile materials are capable of punching up to 8 holes per second.

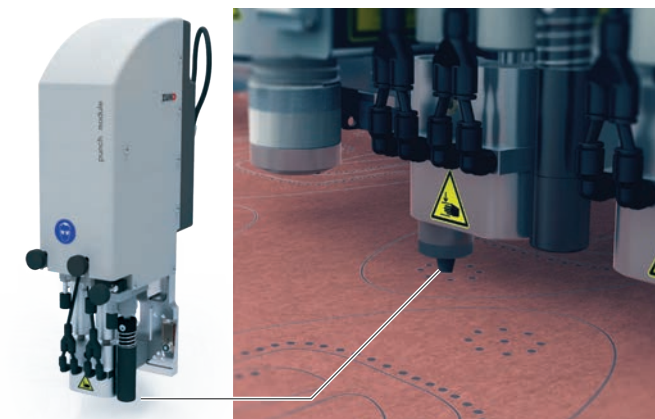

Integrated tool initialization

Fast, precise, efficient: the setup of blades and bits occurs automatically with an integrated tool calibration system. This eliminates any manual steps in determining the proper cutting depth.

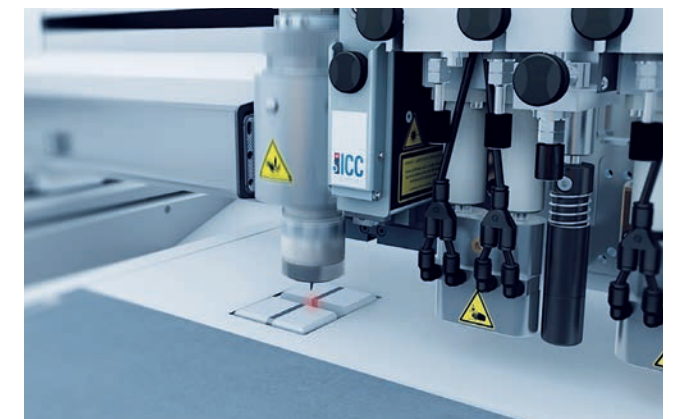

The L3 leather cutter Flexibility at work



Uppers

Cutting and perforating tools designed specifically for leather applications deliver superior performance and productivity.



Sole materials

Rigid, tough materials require powerful cutting tools. Robust blades and the oscillating tools EOT or POT are the perfect combination for processing sole materials.



Stencil materials

Process stencil material of all kinds. For materials that are too tough for cutting, the Zünd tool kit offers just the right routing tool.

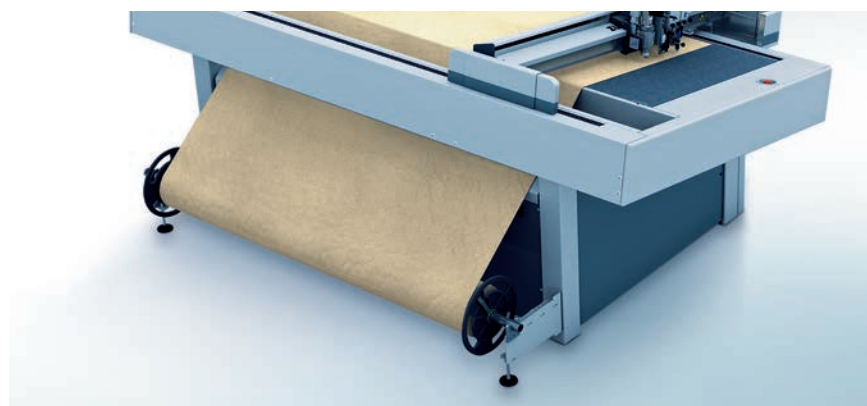

Rolled materials

Is leather processing your primary business? Even if that is the case, would you like to have greater flexibility when using the L3 cutting system? With the optional roll-off unit, you can easily and efficiently process rolls up to a width of 2000 mm/90" and weight of 70 kg/154 lbs.

Solid reasons for Zünd L3



Zünd

Zünd Systemtechnik AG - family-owned and based in Switzerland - specializes in digital cutting systems. The Zünd name represents Swiss quality and has become synonymous with precision, performance and reliability.

Since 1984 we have been designing, producing and marketing modular cutting systems and have gained a global reputation as market leader. The technological superiority of our products stems from our insistence on high quality standards, modular design and focus on our customers.

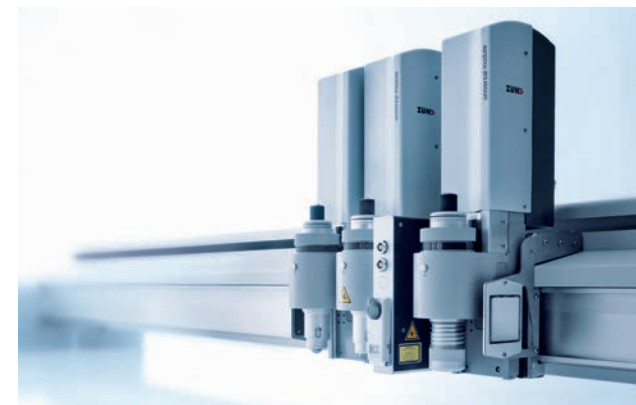

Modularity

Zünd cutting systems are based on a design concept that lends them greater flexibility and adaptability than any others on the market can offer. This unique modularity makes it possible to cost-effectively configure and upgrade Zünd cutters for ever-changing cutting needs. This contributes to their exceptional ROI and makes them retain their value over many years.



Profitability

Solid performance, outstanding quality - thousands of Zünd cutting systems worldwide are producing non-stop and offer daily proof of their unparalleled profitability.

Innovative technology and superior standards of construction guarantee low maintenance costs. Outstanding energy efficiency is yet another benefit of our products. Optimal processing methods, state-of-the-art vacuum generators and sophisticated material-advance systems keep energy demands low and contribute to the eco-friendliness and sustainability of our products.



Worldwide service

What applies to our cutting systems, also applies to our service: Exceptional performance, precision and reliability. Optimally trained and highly experienced specialists are always at your disposal.

Zünd technicians all over the world are only a phone call away. Our subsidiaries and distribution partners in your vicinity strive to keep response times to a minimum and are ready to provide support whenever the need arises.

L3 Cutting Systems

Overview of sizes - active working area

02/2015

L3 C-56
3240 x 1000 mm

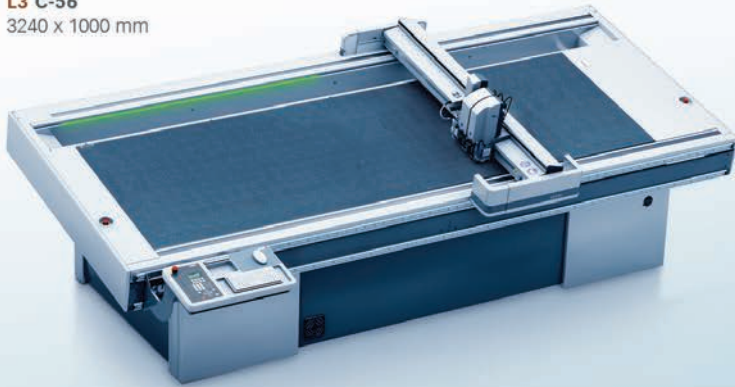

L3 C-40
2300 x 1000 mm

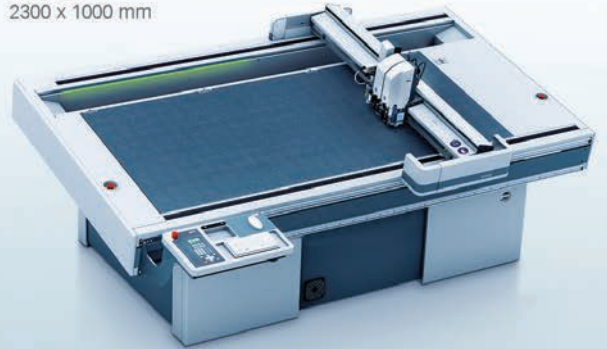

Headquarters
Zünd Systemtechnik AG
Industriestrasse 8
CH-9450 Altstätten
T +41 71 757 81 00
F +41 71 757 81 11
info@zund.com
www.zund.com

ZÜND
swiss cutting systems